

serie/range
MIX



Morella Forni®
morelloforni.com

**Forno a legna
+ piano riscaldato a gas**
*Wood oven
+ gas heated bedplate*



- I forni MIX hanno un funzionamento principalmente a legna, con sistema ausiliario a gas di riscaldamento della platea; possono essere usati solo a legna, o simultaneamente legna + gas.
- La serie MIX appartiene alla famiglia dei forni statici, grazie alla elevata stabilità termica sono ideali anche per cottura di pane e prodotti di gastronomia a fiamme spente.
- I forni MIX sono equipaggiati con sistema ausiliario a bruciatori atmosferici radianti specificamente progettati dalla Morella Forni ed esenti da manutenzione.
- Il cassetto di caduta e raccolta cenere agevola le operazioni di pulizia, migliora la combustione della legna e le condizioni igieniche di cottura.
- Una grande massa refrattaria e la coibentazione sono progettate per elevare il rendimento e diminuire costi di esercizio e perdite di calore.
- Riscaldamento indipendente della platea con gestione e controllo termostatico della temperatura
- il calore sviluppato per il riscaldamento della platea viene veicolato nuovamente all'interno della cupola sfruttandolo nuovamente economizzando i consumi del forno.
- Interfaccia tattile "Inteltouch System".



- MIX ovens are mainly wood ovens, with an auxiliary bedplate gas heating, and can use only wood or wood and gas for their operation.
- MIXs are part of the static ovens' family; thanks to their enhanced thermal stability are perfect for bread or gastronomic products slow baking with no flame.
- MIX ovens are equipped with auxiliary atmospheric gas burners, especially designed by Morella Forni, maintenance-free.

- An external metal drawer collects ashes and debris falling from cooking chamber grooves, to help in keeping the baking area clean, improve wood combustion and overall hygiene.
- The huge refractory mass and extra careful thermal insulation increase oven's efficiency, lower operating costs and heat loss.
- Independent bedplate heating, with temperature-based control system.
- Bedplate heat is redirected into cooking chamber to increase efficiency and lower consumption
- Touch control interface "Inteltouch System".



FORNO STATICO/STATIC OVEN

le finiture della linea/range finishes • **MIX**



Mod./Ref.	Capacità pizze Ø 30 cm./Capacity pizzas Ø 30 cm.	Produzione oraria/Productivity per hour
MIX100	4 pizze	70 pizze/h
MIX110	5 pizze	90 pizze/h
MIX130	8 pizze	130 pizze/h
MIX150	10 pizze	160 pizze/h
MIX180	15 pizze	190 pizze/h

Tabella gas bruciatori forni gas serie "MIX"/ Gas gas burner table "MIX" series gas ovens				Tabella di Riscaldamento a legna serie "MIX"/ Wood heating series "MIX"	
Forno Mod./ Oven Ref.	Potenzialità Gas/ Total gas potential	Consumo/Consumption		Attacchi Gas/ Gas fittings	Potenzialità Legna/ Total Wood potential
		Metano/ Methane (mc/h)	G.P.L./L.P.G. (Kg/h)		
MIX100	7 kW	0,8	0,4	3/4" G	19 kW
MIX110	7 kW	0,9	0,5	3/4" G	21 kW
MIX130	8 kW	1	0,6	3/4" G	27 kW
MIX150	9 kW	1,1	0,7	3/4" G	37 kW
MIX180	10 kW	1,2	0,8	3/4" G	46 kW

certificazioni
certifications

costruiti ed omologati
secondo le norme
manufactured and certified
according to norms



Misure in cm ±2% • Le caratteristiche e i dati riportati nel presente catalogo possono subire variazioni senza preavviso / • Sizes in centimeters ±2% • Data and features in this catalog may change without notice

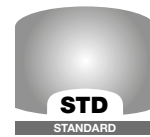
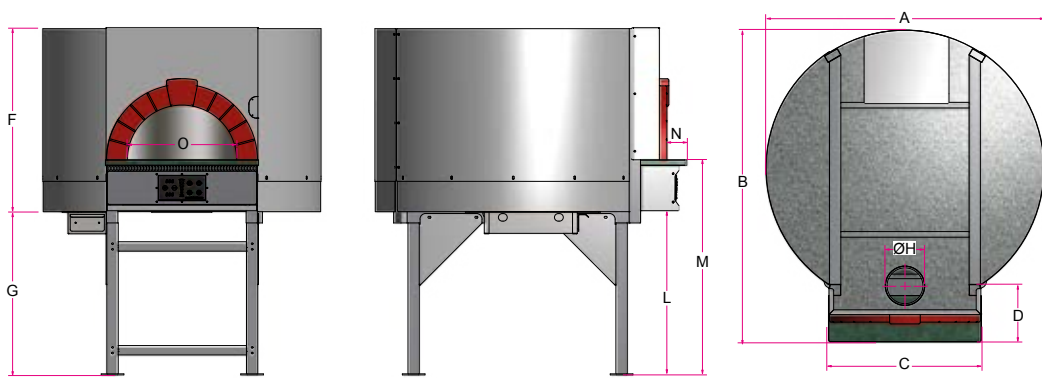

serie
range
MIX

**Forno a legna
+ piano riscaldato a gas
Wood oven
+ gas heated bedplate**

Mod./Ref.	ØH	A	B	C	D	F	G	L	M	N	O	peso/weight (kg)
MIX100	20	138	152	80	29	88	90	88	115	22	45	1150
MIX110	20	148	165	80	29	95	90	88	115	22	45	1400
MIX130	20	168	185	80	29	95	90	82	115	22	50	1650
MIX150	25	188	208	100	35	101	94	82	120	25	50	2350
MIX180	25	220	240	120	35	120	94	82	122	25	80	3500

**FORNO STATICO/
STATIC OVEN**

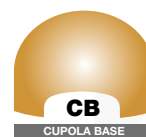
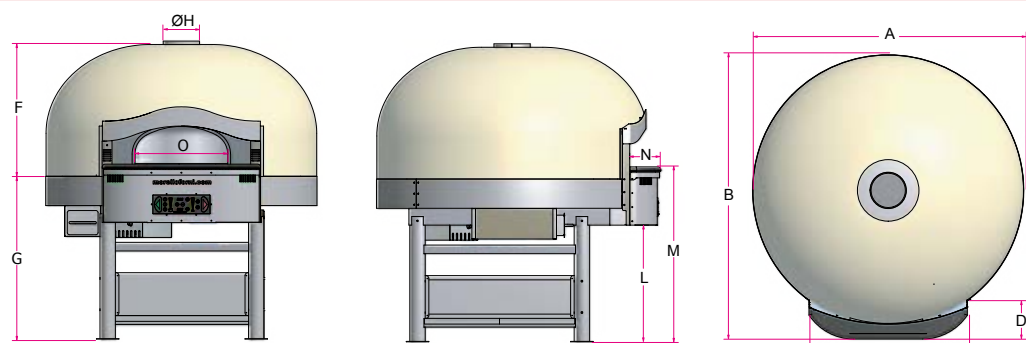

Mod./Ref.	ØH	A	B	C	D	F	G	L	M	N	O	peso/weight (kg)
MIX100	20	150	158	90	22	90	90	88	115	22	45	1200
MIX110	20	160	165	100	22	105	90	88	115	22	45	1550
MIX130	20	180	200	100	22	115	90	82	115	22	50	1950
MIX150	25	200	210	100	24	120	94	82	120	25	50	2450
MIX180	25	230	235	120	24	130	94	82	122	25	80	3650

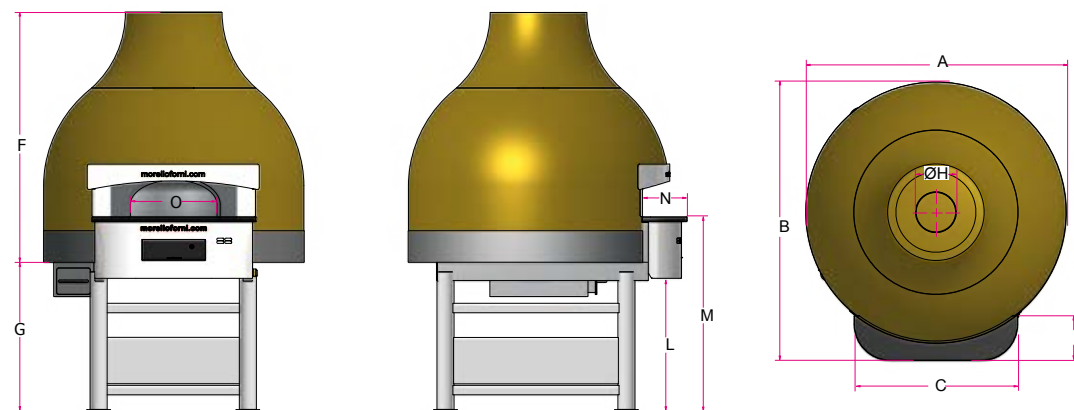

Mod./Ref.	ØH	A	B	C	D	F	G	L	M	N	O	peso/weight (kg)
MIX100	20	154	162	90	22	134	90	88	115	22	45	1300
MIX110	20	160	165	100	22	145	90	88	115	22	45	1700
MIX130	20	180	200	100	22	155	90	82	115	22	50	2200
MIX150	25	200	210	100	24	160	94	82	120	25	50	2700
MIX180	25	230	235	120	24	160	94	82	122	25	80	4000

alcune nostre finiture
some of our
finishes



MORELLO FORMI s.a.s.
Via B. Parodi, 35 - 16014 Ceranesi (Genova) - Italy
Tel. +39 010 7401194 • Fax +39 010 7492194
email: info@morelloformi.com